



# STEPCRAFT.

**Betriebsanleitung.**  
*Construction Manual.*

**Spannbrücken / *Clamping bars***

10/25

Diese Bauanleitung beschreibt die Montage der Spannbrücken für die D-Serie 420/600/840.

*These assembly instructions describe the assembly of the tensioning bridges for the D-Series 420/600/840.*

**Inhalt (Abbildungen nicht maßstabsgetreu) /**  
*Components (illustrations not true scale)*

**1** D.420 – 4x  
D.600 – 4x  
D.840 – 8x



Art.-Nr.: 12692

**Flanschkopfschraube M3 x 8**  
*Flange head screw M3 x 8*  
 Innensechskant / Allen

**2** D.420 – 4x  
D.600 – 4x  
D.840 – 8x



Art.-Nr.: 12686

**Druckfeder**  
*Spring*

**3**



D.420 – Art.-Nr.: 12664  
 D.600 – Art.-Nr.: 12665  
 D.840 – Art.-Nr.: 12666

**2 x Niederhalteleiste**  
*2 x Clamping bar*

**4** D.420 – 2x  
D.600 – 2x  
D.840 – 4x



D.420 – Art.-Nr.: 12667  
 D.600 – Art.-Nr.: 12668  
 D.840 – Art.-Nr.: 12667

**Niederhalteleiste Druckplatte**  
*Clamping bar pressure plate*

**5** D.420 – 6x  
D.600 – 8x  
D.840 – 12x



Art.-Nr.: 12693

**Klemmschraube**  
*Clamping screw*

**Spannbrücken anbringen**  
*Attach clamping bars*

2x

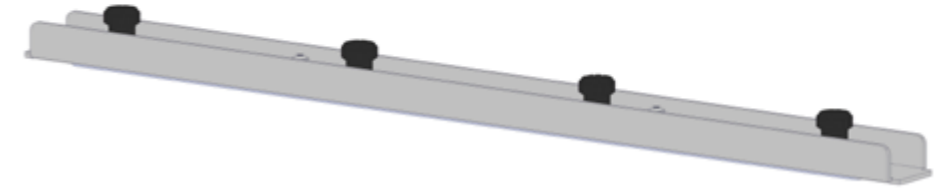

**1**

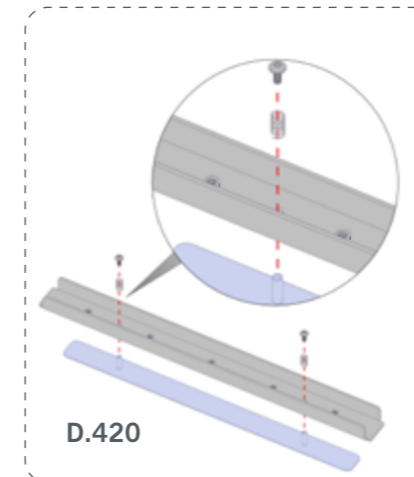

<b>1</b>	<b>2</b>	<b>3</b>	<b>4</b>
M3 x 8			
D.420 = 2x	D.420 = 2x	D.420 = 1x	D.420 = 1x
D.600 = 2x	D.600 = 2x	D.600 = 1x	D.600 = 1x
D.840 = 4x	D.840 = 4x	D.840 = 1x	D.840 = 2x

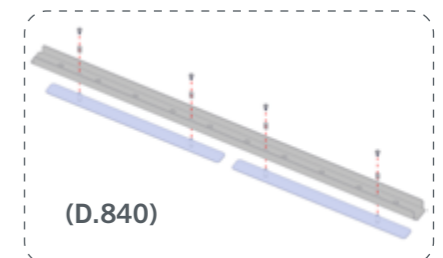
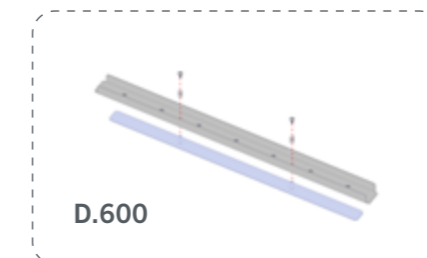

**2**

**5**



D.420 = 3x  
 D.600 = 4x  
 D.840 = 6x

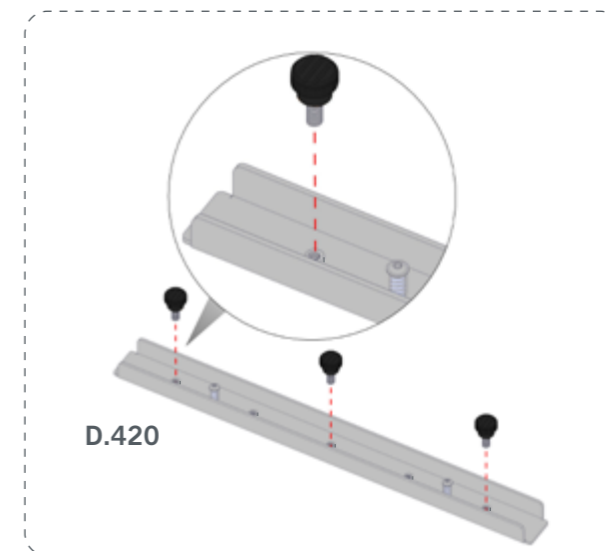

3

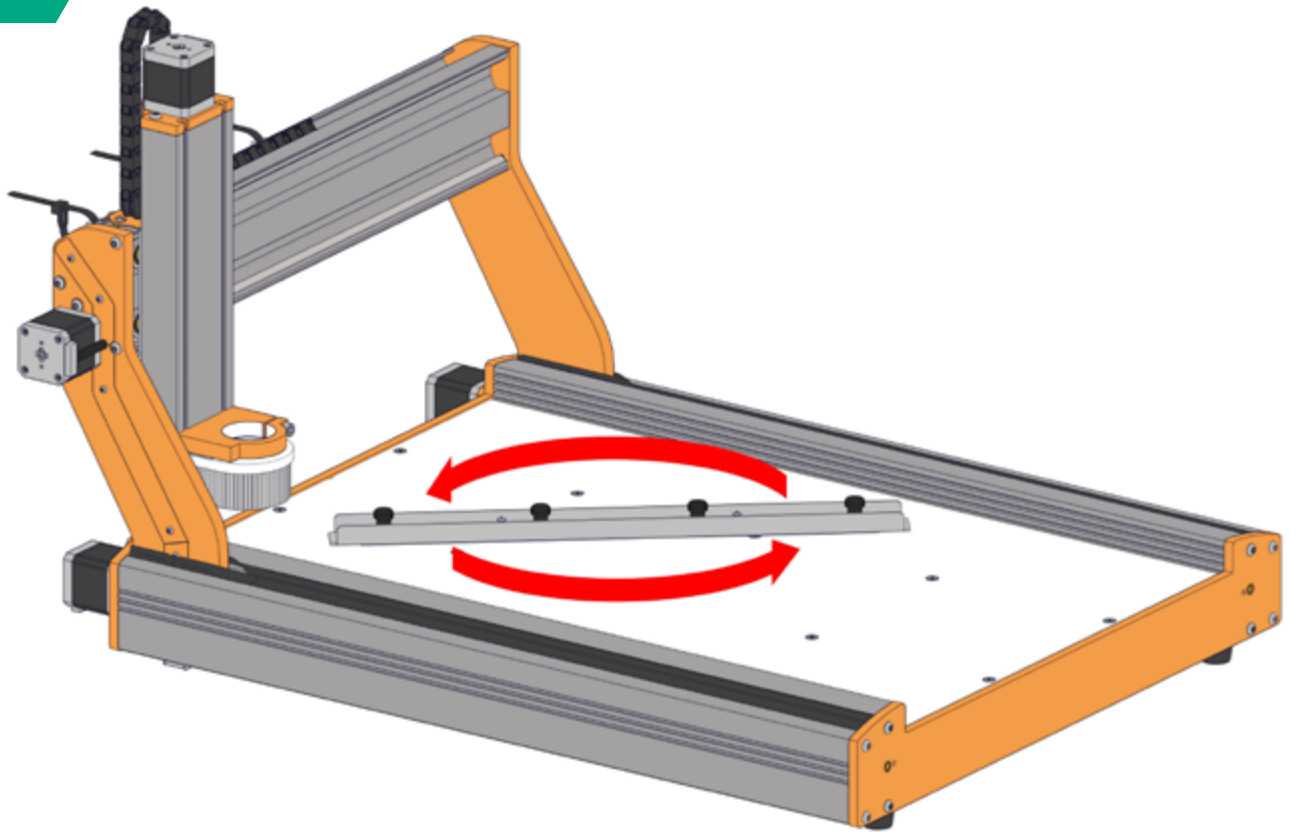

4

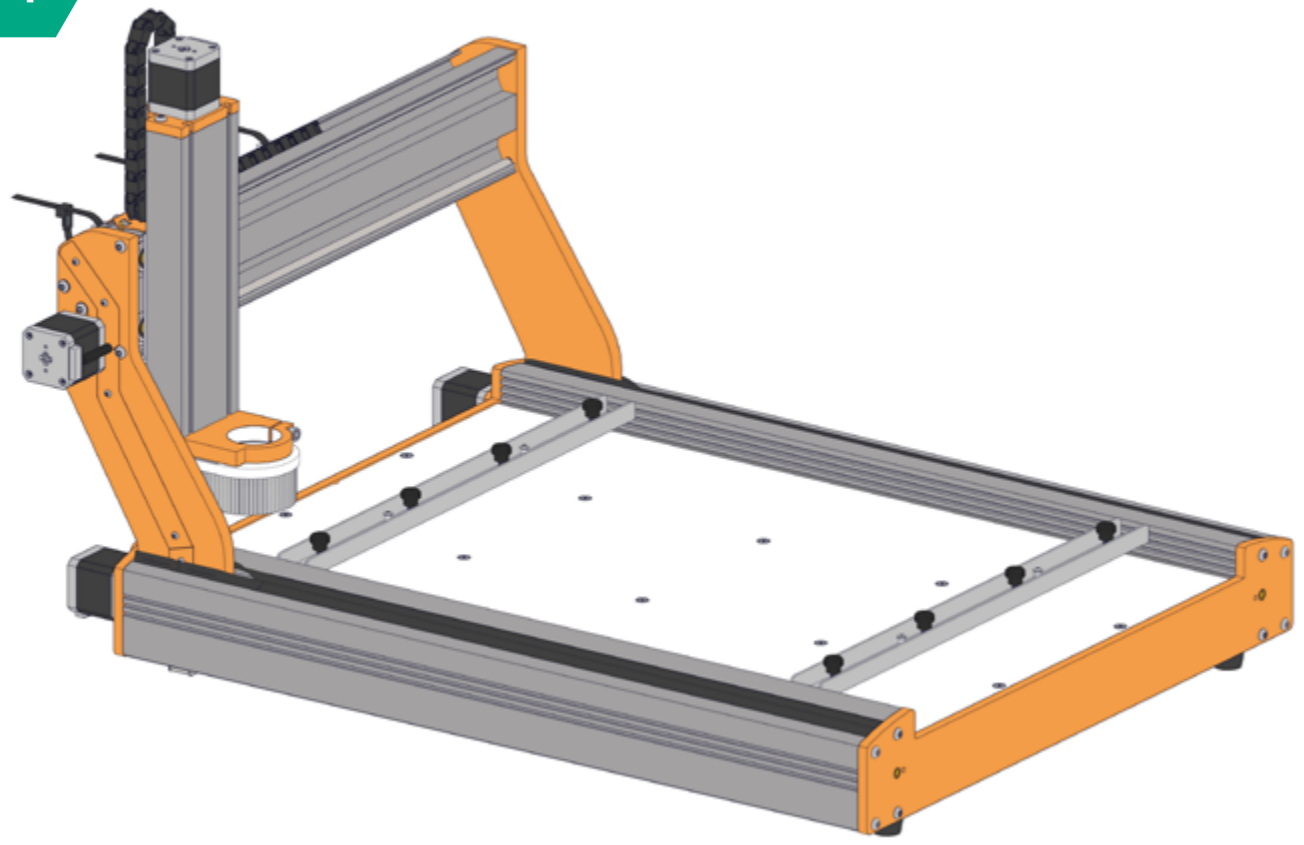





**STEPCRAFT GmbH & Co. KG**

An der Beile 2  
58708 Menden (Sauerland)  
Germany

tel.: +49 (0) 23 73 / 179 11 60  
mail: [info@stepcraft-systems.com](mailto:info@stepcraft-systems.com)  
net: [www.stepcraft-systems.com](http://www.stepcraft-systems.com)



**STEPCRAFT Inc.**

151 Field Street  
06790 Torrington, CT  
United States

tel.: +1 (203) 5 56 18 56  
mail: [info@stepcraft.us](mailto:info@stepcraft.us)  
net: [www.stepcraft.us](http://www.stepcraft.us)